

HOW TO USE 24 VDC GTV-I POWER SUPPLY



Explanation of symbols

You will find the following symbols on the packaging, in the manual and on this product:



1



2



3



4

The meaning of these symbols as follows:

- | | | |
|---|-----------|---|
| 1 | WARNING | : The surface may feel warm |
| 2 | ATTENTION | : Read the instructions in the manual first |
| 3 | CAUTION | : Extra attention is drawn to a particular action |
| 4 | ATTENTION | : User tip |

Introduction

This document describes the assembly and commissioning of Electroproject's GTV-I power supply unit.

Applications of the GTV-I power supply.

The GTV-I is designed for situations where doors must open or close in a controlled manner in response to alarm signals or user commands.

Closed internal doors on the shop floor in buildings are often inconvenient for the performance of daily work. They are therefore held open using door magnets or electric door closers. These door magnets and closers are powered by a magnetic power supply. In the unlikely event of a fire, the fire alarm control panel (FAC) switches off the magnetic power supply. The doors will then be closed by a (mechanical) door closer.

Depending on the application and type of load, a GTV-I power supply unit can be used with a TX... Time Xtender module or GTV-BU power supply unit (with battery back-up). These power supplies are housed in a solid metal enclosure, which features an ON/OFF push-button. By applying a control signal from the FAC, in the form of a break contact or a 24V DC signal, the power supply is switched on or off.

With its 2 independently switched outputs, 18 programme options and 2 test programmes, the power supply provides a highly cost-effective solution for controlling and disconnecting, among others:

APPLICATIONS:

- Pedestrian doors : Independent control of pedestrian doors divided over 1 or 2 corridors (zones).
- Double doors : Door closing sequence control for double swing doors. (TX-1 backup option)
- Internal doors : Sliding, or rolling doors with special door magnets and/or signalling.
- Other systems : Control of smoke vents, fire dampers and standalone smoke switches.
- Escape doors : Doors with locking magnets with fixed and switched power supply for locking and position signalling.

Application examples:

The combination of functions allows a wide range of applications for the GTV-I power supply unit.

Detailed application examples can be found in the GTV-I application manual at www.Electroproject.nl or contact Electroproject, phone +31 88 484 9250.

Contents

- 1 General
 - 1.1 Precautions and safety instructions
- 2 Delivery package
- 3 Regulations
- 4 Description of the GTV-I power supply
 - 4.1 Transmission monitoring and status indication
- 5 Installation of the GTV-I
 - 5.1 Borehole dimensions
- 6 Connecting the power supply
 - 6.1 Connecting external components
 - 6.2 Connecting the load
 - 6.3 Connecting the control current inputs
 - 6.4 Connecting the control current outputs
 - 6.5 Cable losses
- 7 Jumper setting
 - 7.1 Sample applications for programmes 0 - 9
 - 7.2 Detailed programme description 0- 9
 - 7.3 Detailed programme description 10-19
- 8 Commissioning the GTV-I
 - 8.1 Input and output status LEDs on the control board
 - 8.2 Disabling the push-button function on the housing
 - 8.2 Reset push button on control board
 - 8.3 Three-wire connection of 2 load circuits
 - 8.4 Forwarding of operational messages
 - 8.5 Master/follower line coupling
- 9 Status messages on the GTV-I
- 10 Maintenance and management
 - 10.1 Service and maintenance
- 11 Warranty
- 12 Technical specifications
 - 12.1 Dimensions and weights
- 13 Spare parts and options
- 14 CE marking and RoHS declaration
- 15 Contact Electroproject

1 General

This manual is intended for authorised installers who install and commission the GTV-I power supply units. The instruction manual describes the assembly, installation, operation and primary maintenance of the Electroproject GTV-I power supply unit.

Electroproject is not liable for any consequences arising from possible inaccuracies or omissions in this installation manual.

Electroproject reserves the right to change its products without prior notice.

1.1 Precautions and safety instructions

For safe and reliable operation of the GTV-I, it is essential that installation and commissioning are carried out exclusively by qualified personnel. Such personnel are assumed to be familiar with the applicable installation regulations and all relevant statutory requirements.

In the event of problems during commissioning or in the event of malfunctions, please contact the Electroproject helpdesk on +31 (0)88 484 92 83.



PLEASE NOTE: The power supply unit is powered by hazardous voltage. (230 V AC)

- Ensure the GTV-I is in good and undamaged condition before use.
- The GTV-I may only be commissioned by qualified personnel.
- Observe local electrical installation regulations.
- Switch off power supply before carrying out any work on this unit.
- The power cable must be equipped with a permanently installed disconnect device that is easily accessible.
- The GTV-I must not be overloaded. On delivery, the output current should be measured.
- Observe the polarity of the load due to the freewheeling and blocking diodes in the magnets and other components to be connected.
- The GTV-I should be placed in a sufficiently dry room and be kept dry during operations.
- Keep the GTV-I door closed at all times to prevent unauthorised access.

Each GTV-I has a type number sticker on the inside of the housing. Check that this GTV-I meets the requirements of its intended application (e.g., output voltage, nominal output power).

2 Delivery package

The GTV-I is delivered ready to use. The package consists of the following:

- GTV-I power supply unit
- Plastic housing key
- 3 cable glands M16 and 2 cable glands M12
- 3 blind cable glands M16 and 2 blind cable glands M12
- GTV-I User Manual
- Drill template combined with abbreviated commissioning procedure
- Recyclable cardboard packaging

The following components are not included and must be installed by the installer in compliance with all applicable regulations:

With a flexible connection:

- A connecting cable with a protective plug, suitable for at least 230 V AC / 6 amps.

With a fixed connection:

- A connecting cable, combined with a main switch for de-energising the GTV-I. The main switch can be placed in the GTV-I housing on the DIN rail if desired.

Power overview GTV-I 24 V DC power supplies

Type	Maximum current	Maximum power
GTV-I 25	1 A	25 W
GTV-I 50	2 A	50 W
GTV-I 100	4 A	100 W
GTV-I 250	10 A	250 W

3 Regulations

Provisions applicable directly and indirectly.

- NEN 1010 :2020 +C1:2024
- NEN 2535: 2022
- Fire Protection Installations 2nd print Feb. 2010
- Environmental Planning Decree (Bbl - Dutch Building Decree 2021)
- Local fire regulations

According to NEN 2535 chapter 8.6, the GTV-I falls into category H. In this context, the GTV-I has a direct or indirect relationship with compartmentation, evacuation and electrical unlocking of doors.

The door retention device (door magnet, door closer or linear locking magnet) must comply with EN1155:

- The operating voltage for these installations must be 24 volts DC.
- The installation must be carried out in accordance with NEN 1010.
- For partial verification of operation and manual door closing, there must be a means to manually release the locking mechanism. For example, this can be achieved by using magnets with release push-buttons or installing an unlock button at the door.
- The control of electric door locks linked to a fire alarm system must be automatically tested at least once every 24 hours to ensure correct operation.
- When using a double door with a stop, a specific closing sequence must be followed. This is to prevent these doors from closing in the wrong order, which would compromise the fire and/or smoke resistance of the installation.
- Not all doors need to be unlocked when triggered by a fire alarm system. It is often preferable to close doors in a specific area (corridors, floors). In doing so, the relevant detection zones (detector circuits) of the fire alarm system must be taken into account.

Transmission path monitoring:

- NEN 2535:2022 contains specific provisions on the electrical monitoring of the cabling between the fire alarm control panel and the door control system. These provisions emphasise ensuring the reliability and integrity of cabling so that the fire alarm system functions correctly in the event of a fire. The standard requires the cabling to be continuously monitored for interruptions and short-circuits, and any faults must be immediately detected and reported to the fire alarm control panel. This means that the fire alarm control centre is responsible for monitoring the integrity of this cabling to ensure that the system functions correctly in the event of fire.
- Moreover, NEN 2535:2022 requires that the control of door locking systems be tested at least once every 24 hours to verify correct operation. This testing is possible by disconnecting the GTV-I from the FAC or, if this is not possible, by installing a timer in the GTV-I power supply and checking whether all doors actually close (GTV-I switches off).

4 Description of the GTV-I power supply

Application

The GTV-I power supply unit is designed for powering door magnets, door closers and electric locks used in combination with an external control unit (e.g. a fire alarm control panel).

Principle of the GTV-I

The GTV-I consists of a switched-mode power supply, a control board, and a membrane push-button with indicators, all assembled in a robust sheet steel enclosure. The power supply has high efficiency and long service life. The sum of ripple voltage and noise is less than 1%. The primary voltage may range from 180 to 240 volts (50/60 Hz). The output current may vary from 0 to 100% continuous. The nominal output voltage is set to 25 V DC to partially compensate for voltage drop in long cable lengths.

Key features of the GTV-I power supply unit:

- Switched outputs protected against short-circuit-proof by automatic overcurrent detection
- Load indicator on the control board for visual display of connected load
- Selector switch with 2 x 10 programme options.
- 5 inputs, and 2 switched-mode power outputs (24 V DC)
- 1 fixed 24 V DC output 300 mA separately fused,
- DIN-rail mounting space serving customer-specific option modules,
- Suitable for connection of Super Cap Back-Up TX time Xtender modules
- Large and easily accessible connection terminals,
- Output power supply is stabilised and smoothed,
- Backward compatible with previous GTV, GTVS and GTV-A models,
- Status LED indication on the control board of all inputs and outputs (quick check of operation),
- Jumper setting for disabling the function of the foil push button on the housing,
- Option for *manual/auto restart* after reset of fire alarm/BMS contact,
- Master/follower output function allowing simultaneous control of multiple units,
- A single universal control board for all GTV-I models (easy for repairs/maintenance),
- Cable entry selectable from top or bottom.

Automatic overload detection

The GTV-I features fast and accurate overload detection. In the event of overload, the output voltage is switched off. This condition is indicated by the *slow flashing of the amber LED on the housing door* (and two LEDs on the control board). Once the fault has been resolved, the GTV-I will have to be manually reset using the reset push-button on the control board in the housing or by disconnecting the power supply if no TX time Xtender is used.

4.1 Transmission path monitoring and status indication

The GTV-I has one potential-free signal contact per output for status reporting to the fire alarm control panel (FAC) or the BMS. The contacts of the 2 outputs can be switched in series or parallel with the fault contact as required.

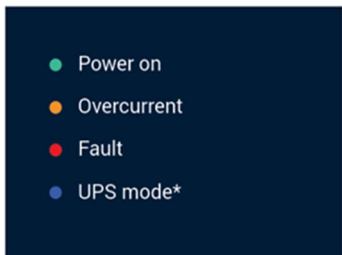
	<p>LED indicator on the door</p> <p>The new front layout with four-colour LED status indicators and integrated push-button controls makes operation and status diagnosis extremely easy.</p>
---	--

5 Installation of the GTV-I

When installing the GTV-I, make sure there is adequate ventilation around the housing. If there is insufficient ventilation, or if the ambient temperature rises too high, the power supply may have a reduced load capacity. Maintain a minimum clearance of 10 cm on all sides of the GTV-I.

5.1 Borehole dimensions

The wall should be flat and solid enough to support the GTV-I. The GTV-I has four mounting points with 6 mm boreholes, accessible from inside the housing. The drilling template provided can be used to mark the boreholes for the GTV-I.

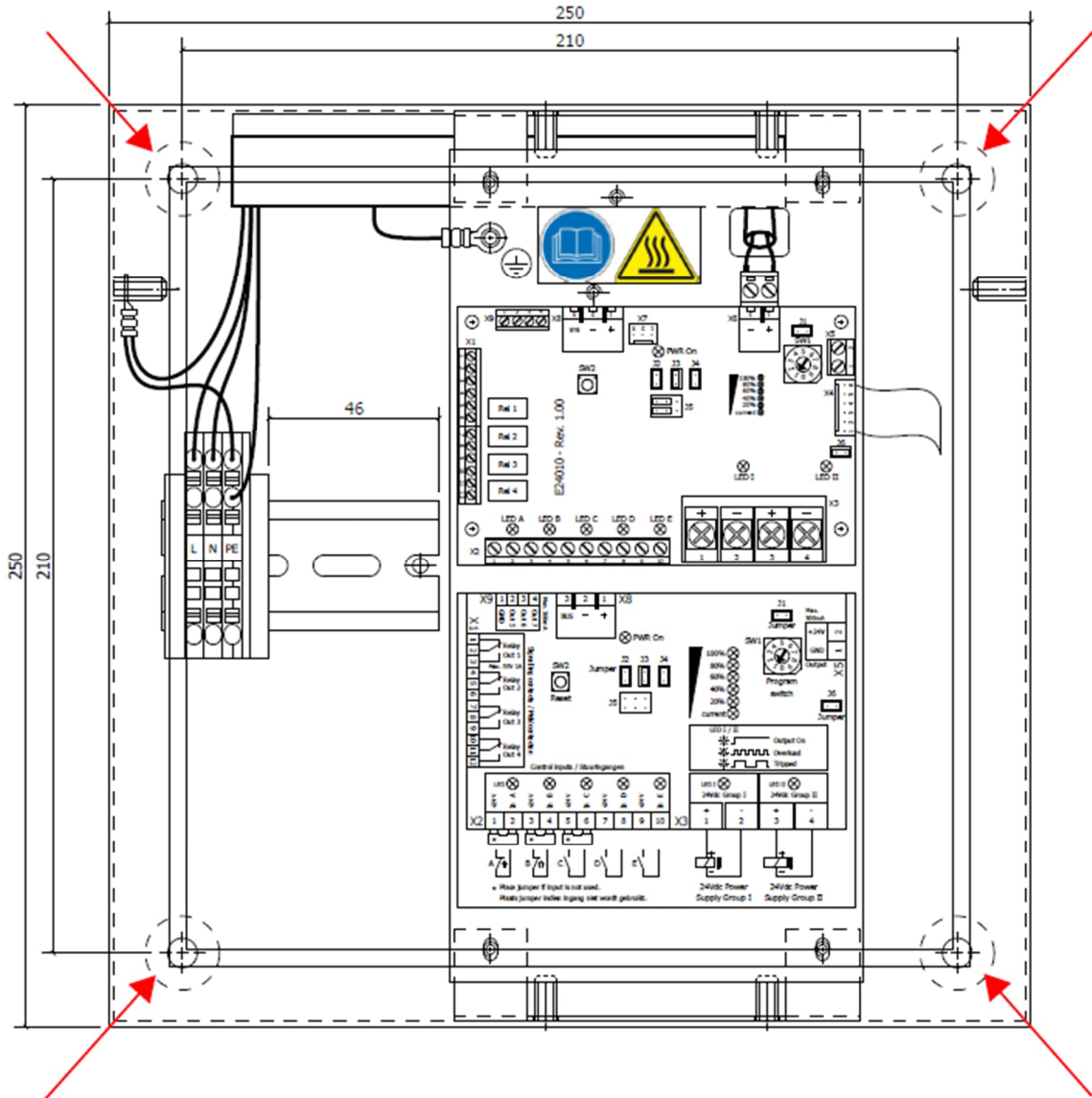

Dimensions:

Type	Power supply dimensions (wxhxd) in mm	Borehole dimensions (wxh) in mm	Weight in kg	Packaging dimensions (wxhxd) in mm
GTV-I 25	250 x 250 x 120	210 x 210	4.5	310 x 310 x 190
GTV-I 50	300 x 250 x 120	260 x 210	5.0	360 x 310 x 190
GTV-I 100	300 x 250 x 120	260 x 210	5.5	360 x 310 x 190
GTV-I 250	400 x 250 x 155	360 x 210	7.0	460 x 310 x 230

6 Connecting the power supply

- The GTV-I power supply is suitable for a mains voltage of 180V - 240V, 50/60Hz.
- Electrical connection is possible via a flexible, or fixed connection.
- The GTV-I must be connected to earth.

Connection to a 1-phase grid.

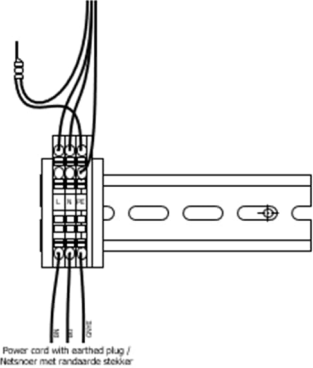
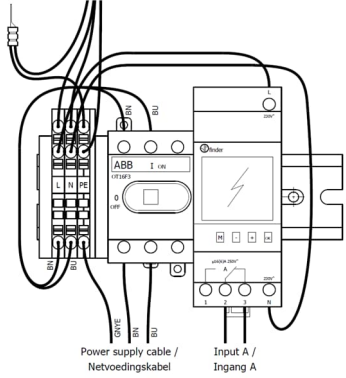
 <p>Power cord with earthed plug / Netstoer met randsaarde stekker</p>	<p>With a flexible connection:</p> <ul style="list-style-type: none"> • A 3-conductor power cord with earthed plug suitable for at least 6 amps. • An electrical connection with earthed socket (WCD) 230 VAC is required for the power supply of the GTV-I. • It is recommended to connect the power supply to a separately protected circuit so that other faults in the installation do not directly affect the proper operation of the power supply.
 <p>Power supply cable / Netvoedingskabel</p> <p>Input A / Ingang A</p>	<p>With a fixed connection:</p> <ul style="list-style-type: none"> • Fixed cable connection with main switch in the power cable to allow the GTV-I to be de-energised. (See NEN 1010) • The main switch can be built in if required in the GTV-I housing on the DIN rail next to the power supply terminals. • Example: ABB OT16F3 DIN-rail main switch with Finder time switch with power reserve.

6.1 Connecting external components

Free installation space with DIN rail (TS35) for additional components.

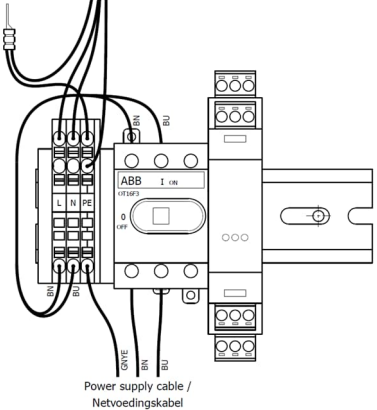

Power supply cable /
Netvoedingskabel

- All GTV-I power supplies are equipped with a DIN rail (length according to size of housing). Required components can be mounted as required. Examples include: a main switch, time switch, I/O control module, an additional relay or terminal blocks.
- If necessary, install the main switch and I/O unit of the FAC directly next to the power terminals on the DIN rail.
- The power terminals on the DIN rail provide an additional 230-volt connection as standard, which can be used to power a time switch.

Connecting the TX Super Cap Back-Up modules and GTV- I BU battery units

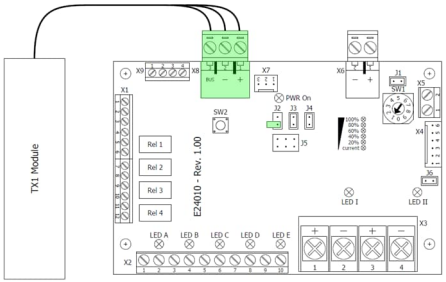

- The GTV-I can be connected to TX Supercap modules or a GTV-I BU battery back-up unit via the power supply control board. See terminal block X8 at the top of the control board.

In the event of a mains power interruption, these modules continue to supply the GTV load for a short or extended period, allowing any emergency power supply to start up and, if necessary, programmes to be shut down in a controlled manner.

- TX modules and GTV-I BU units are supplied with connector.

6.2 Connecting the load

Connection:

- For both power outputs, check the current drawn via the load indicator.
- Note the polarity of the load to be connected. Most magnets or door closers are polarity-sensitive and have a built-in freewheeling and blocking diode!
- Work on the GTV-I must be carried out in a sufficiently dry environment.
- Never operate the GTV-I with the door open unless control and adjustment work needs to be carried out.

Terminal block assignment X3

Terminal number	Power outputs	Function dependent on programme selection
Terminal 1	+ 24 V DC	Switched power output circuit I
Terminal 2	- GND	
Terminal 3	+ 24 V DC	Switched power output circuit II
Terminal 4	- GND	

Terminal block assignment X5

Terminal number	Auxiliary power outputs	Function
Terminal 1	+ 24 V DC	Fixed 24 V DC output maximum load 300mA
Terminal 2	- GND	

Both power outputs terminal block X3 (circuits I and II) are capable of switching the GTV-I's total maximum current.

PLEASE NOTE: The total current from the four 24V outputs (X3 and X5 together) may not exceed the maximum current of the GTV-I.

6.3 Connecting the control inputs

The diagram shows the internal wiring of the GTV-I control panel. It includes terminals X1 (12 signalling contacts), X2 (10 control inputs), X3 (24Vdc power supply groups), X8 (power on/off), X9 (master output), and X10 (status signal). It also shows a program switch (SW1) with a current scale, a reset button (SW2), and various jumpers (J1-J6). The control inputs A-E are connected to 24Vdc power supplies.

Inputs A to E can be controlled by either a potential-free contact or an external +12-24V DC power supply. See also Chapter 8.5 Master/follower line coupling.

Connection:

- The GTV-I power supply has five inputs (A, B, C, D and E) that together, depending on the position of the function switch, determine how the two 24V outputs (Circuits I and II) and the 3 digital outputs are controlled.
- As soon as one of the 24V power outputs becomes active, the corresponding "output" relay will close a potential-free contact. This contact is available on terminal block X1 *Signalling contacts* (Output I and Output II). This allows the controlling device to receive a status signal.
- Master output X9 (terminals 1 and 2) can be used to control other GTV-I power supplies. See wiring diagram on page 20

Terminal block assignment X2 (for programme 0-9)

Terminal number	Inputs	Function dependent on programme selection
Terminal 1	Fire contact zone 1	If input A closed:
Terminal 2		Blue LED A on
Terminal 3	(Fire contact) zone 2	If input B closed:
Terminal 4		Blue LED B on
Terminal 5	Fire, clock or external contact	If input C closed:
Terminal 6		Blue LED C on

Terminal block assignment X2 (extended in combination with programme 10 -19)

Terminal number	Inputs	Function dependent on programme selection
Terminal 7	External control e.g. push button (OEM) application	If input D closed:
Terminal 8		Blue LED D on
Terminal 9	External control e.g. push button (OEM) application	If input E closed:
Terminal 10		Blue LED D on

See also the detailed programme description in chapters 7.1 and 7.2

6.4 Connecting control current outputs

Connections on the control board

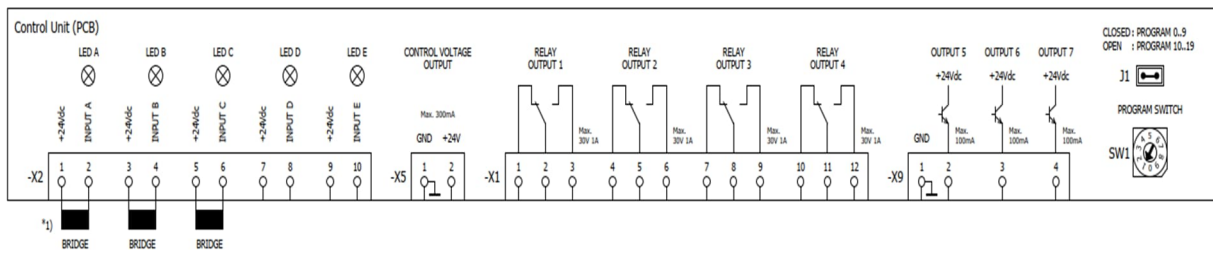

Terminal block assignment X1

Terminal number	Relay outputs	Function in combination with programme selection 0 to 19
Terminal 1 (NC)	Relay Out 1 -Change contact Max 30 Volt 1 Amp	If output 1 active: Relay Out 1: Terminals 2 and 3 closed
Terminal 2 (COM)		
Terminal 3 (NO)		
Terminal 4 (NC)	Relay Out 2 - Changeover contact Max 30 Volt 1 Amp	If output 2 active: Relay Out 2: Terminals 5 and 6 closed
Terminal 5 (COM)		
Terminal 6 (NO)		
Terminal 7 (NC)	Relay Out 3 -Change contact Max 30 Volt 1 Amp	If there is a fault: Relay Out 3: Terminals 7 and 8 closed
Terminal 8 (COM)		
Terminal 9 (NO)		
Terminal 10 (NC)	Relay Out 4 -Change contact Max 30 Volt 1 Amp	If control current/mains voltage is missing Relay Out 4: Terminals 10 and 11 closed
Terminal 11 (COM)		
Terminal 12 (NO)		

Terminal block assignment X9

Terminal number	Digital outputs	Function in combination with programme selection 0 to 11*
Terminal 1	- GND	Comon negative terminal
Terminal 2	+24 V DC Max. 100 mA	Output 5: Master output active If input A and C closed
Terminal 3	+24 V DC Max. 100 mA	Output 6: Output active If UPS connected
Terminal 4	+24 V DC Max. 100 mA	Output 7: Output active If UPS operating

*Note

Function of terminal block X9 in combination with programme selection 12–19, depending on the chosen programme.

6.5 Cable losses

Sample table:

Offered voltage (in volts) at full load at the end of the cable for different cable lengths and conductor cross-sections.

GTV-I type number: Rated current	GTV-I 25 1 A				GTV-I 50 2 A				GTV-I 100 4 A				GTV-I 250 10 A			
Conductor cross-section in mm ²	Distance (metres)				Distance (metres)				Distance (metres)				Distance (metres)			
	0	25	50	100	0	25	50	100	0	25	50	100	0	25	50	100
0.8	25.0	23.9	22.8	20.6	25.0	22.8	20.6	16.3	25.0	20.6	16.3	7.5	25.0	14.1	3.1	0
1	25.0	24.1	23.2	21.5	25.0	23.3	21.5	18	25.0	21.5	18	11	25.0	16.3	7.5	0
1.6 *	25.0	24.5	23.9	22.8	25.0	23.9	22.8	20.6	25.0	22.8	20.6	16.3	25.0	19.1	14.1	3.1
2.5	25.0	24.7	24.3	23.6	25.0	24.3	23.6	22.2	25.0	23.6	22.2	19.4	25.0	21.5	18	11
4	25.0	24.8	24.6	24.1	25.0	24.6	24.1	23.3	25.0	24.1	23.2	21.5	25.0	22.8	20.6	16.3

The formula used for this calculation is:
$$U_v = \frac{2 \times L \times I \times \rho}{A}$$

Where:

- U_v Voltage drop of the cable in volts
- L Length of cable in metres
- I Current flowing through the cable in amperes
- ρ Resistivity of the cable conductors (in this case copper, i.e. 0.0175 $\Omega \cdot \text{mm}^2/\text{m}$)
- A Conductor cross-section in mm^2

*In practice, 4-core 0.8 mm² signal cable is frequently used, with the cores connected in pairs in parallel.

Example: Voltage loss indication:

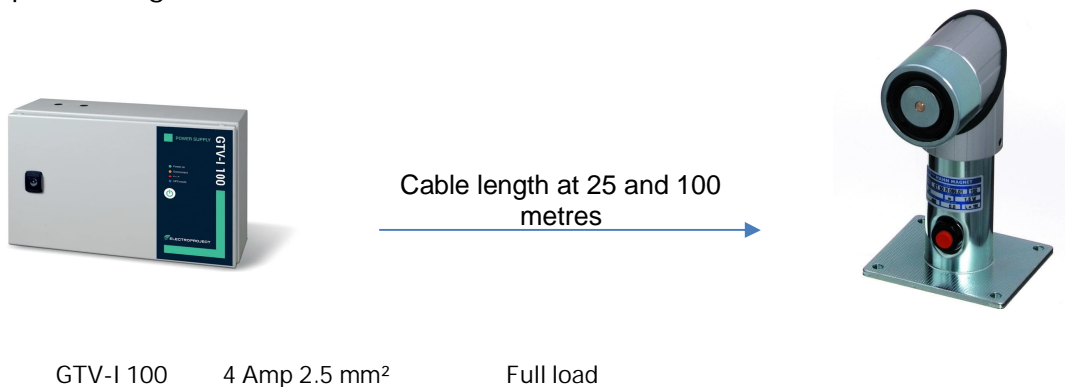

The open terminal voltage of all GTV-I power supplies is 25V DC, to compensate for voltage drop. When using 25 metres of connection cable with conductor cross-section 2.5 mm², the terminal voltage at a nominal load of the GTV-I 100 will be 23.6 V DC, according to the above table.

If the distance becomes 100 metres, the terminal voltage on the magnet will have dropped to 19.4 V DC.

Note:

The above table is indicative. For an exact calculation, the voltage drop along the cable needs to be calculated for each partial load if the load is distributed along the entire cable.

7 Standard jumper setting J1 to J6

The GTV-I has 6 jumpers marked in green.
The position indicated is the default value set at the factory on delivery.

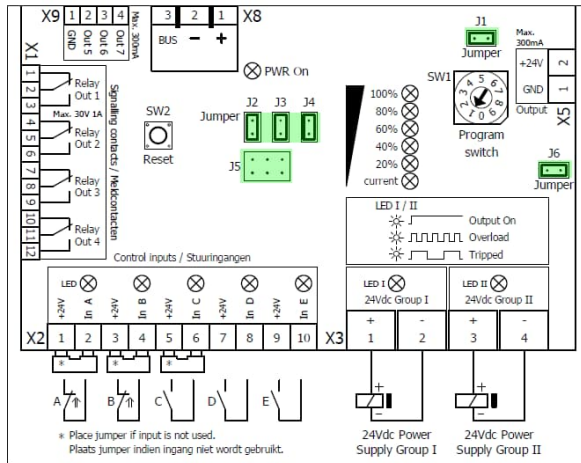

Jumper J1 programme selection example

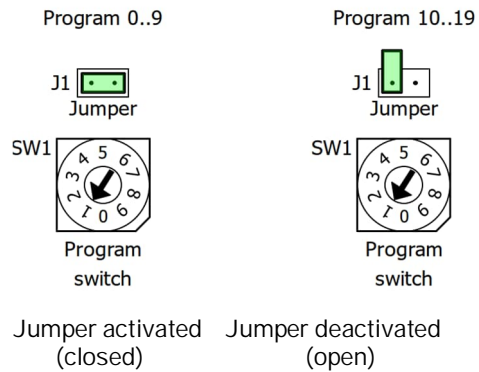

Jumper settings overview

Jumper	Meaning	Recommended action
J1	Programme choice The GTV-I has 2 sets of 10 pre-programmed drivers which can be selected by setting the function switch on the control board.	To select the second set (10-19), jumper J1 must be opened.
J2	Super Cap TX-1 backup (optional) The SuperCap module provides temporary power in the event of a power failure. Ideal for controlled evacuation procedures or when bridging start-up of an emergency power supply (UPS).	To activate the TX modules, jumper J2 must be removed.
J3	Reset push button SW2 SW2 serves as a reset button in the event of faults and as an internal ON/OFF push button. (If Reset: press the push button for 3 seconds)	To deactivate the internal ON/OFF function, jumper J3 must be opened
J4	Self-test routine The GTV-I features a comprehensive self-test routine that measures whether the GTV control board is still functioning 100% properly.	To deactivate this function, jumper J3 must be opened.
J5	Trip value of automatic current detection This jumper setting is factory set and lacquered.	These jumpers may not be changed.
J6	Switch off push-button function on housing door Using the Foil push button on the door, the GTV-I can be switched on and off manually.	To deactivate this function, jumper J4 must be opened.

7.1 Example applications for programmes 0 - 9

Setting the function switch

- The function switch for setting programmes 0 to 9 and 10 to 19
- The power supply automatically switches ON in operating modes 1 to 4 and 9.
- The power supply switches ON manually in operating modes 5 to 8.
- With the push button (PB) you can switch the power OFF and ON again.



Programmes	Description	Sample applications
0 and 10	Switch on outputs I and II independently of the status of the inputs.	Testing of output functions without dependence on inputs with the push button.
1 and 5	Switching 1 load (zone) ON and OFF simultaneously via output I and II.	Simultaneously close all doors on multiple floors/sections.
2 and 6	Two loads (zones) via outputs I and II switched on simultaneously and switched off with a delay.	Shutting down double doors with a specific closing sequence control, or emergency doors with pre-signalling in combination with a TX-1 Time Xtender.
3 and 7	Two loads (zones) switched separately on and off via outputs I and II.	Control the doors in segments per section to keep escape routes open longer.
4 and 8	Two loads (zones) switched separately on and off via outputs I and II, with output II protected against switch-off.	Be able to control pedestrian doors and emergency doors and/or secure sections separately, each with their own switch-off protocol.
9	Two loads (zones) switched on sequentially with a delay via outputs I and II, and switched off simultaneously.	Delayed switching on of two loads with high inrush currents to avoid peak load.

If you want to switch on the power supply MANUALLY after resetting the inputs, set the function switch to the position shown below:

Auto reset	Manual reset (PB)	Comment
0	0	See also the detailed programme descriptions 10 to 19 on page 18
1	5	
2	6	
3	7	
4	8	
9	-	

Detailed descriptions of all programmes can be found in chapter 7.1

For sample applications, download our sample application manual at www.electroproject.nl under GTV-I power supplies.

TX-1 Time Xtender module

	<p>Time Xtender Super-cap backup suitable for DIN-rail mounting.</p> <ul style="list-style-type: none"> • If the TX-1, 2,3 or 4 module is connected, all loads and the control board are backed up by at least 20+ seconds depending on the type, load and programme selected. See the TX time Xtenders leaflet at shop.electroproject.nl.
--	---

7.2 Detailed description of programme 0 to 9

Function switch position 0: programme 0

<i>Switch on outputs I and II independently of the status of the inputs. (Test programme)</i>		
Desired function	Input conditions	Results
Switch on outputs I and II	Operate PB	Outputs I and II active
Switch off outputs I and II	Operate PB	Outputs I and II fail

Function switch position 1: programme 1

<i>1 load (zone) switched on and off simultaneously via outputs I and II</i>		
Desired function	Input conditions	Results
Switch on outputs I and II	Close inputs A, B & C	Outputs I and II active
Switch off outputs I and II	Interrupt input A, B or C or operate PB	Outputs I and II fail

Function switch position 2: Programme 2

<i>Two loads (zones) via outputs I and II switched on simultaneously and off with a delay. (Closing sequence control: see Note*)</i>		
Desired function	Input conditions	Result: See Note*
Switch on outputs I and II	Close inputs A, B & C	Outputs I and II active
Switch off outputs I and II	Interrupt input A, B or C or operate PB	Output I fails Output II fails after 6 sec.

Function switch position 3: Programme 3

<i>Two loads (zones) switched on and off separately via outputs I and II.</i>		
Desired function	Input conditions	Results
Switch on output I	Close inputs A & C	Output I active
Switch off output I	Interrupt input A or C or operate PB	Output I fails
Switch on output II	Close inputs B & C	Output II active
Switch off output II	Interrupt input B or C or operate PB	Output II fails

Function switch position 4: Programme 4

<i>Two loads (zones) switched on and off separately via output I and II, with output II protected against disconnection</i>		
Desired function	Input conditions	Results
Switch on output I	Close inputs A & C	Output I active
Switch off output I	Interrupt input A or C or operate PB	Output I fails
Switch on output II	Close input B	Output II active
Switch off output II	Interrupt input B	Output II fails

Function switch position 9: Programme 9

<i>Two loads (zones) via outputs I and II switched on with a delay and off simultaneously.</i>		
Desired function	Input conditions	Results
Switch on outputs I and II	Close inputs A, B & C	Output I active and output II follows after 6 seconds
Switch off outputs I and II	Interrupt input A, B or C or operate PB	Outputs I and II fail

Note: *

For controlled shutdown in the event of a mains power failure, a TX-1 Time Xtender or UPS back-up is required.

- If a TX module is connected to the control board, programmes 0 to 9 are backed up for at least 20 seconds in the event of a power failure.
- If a GTV-BU unit is connected to the control board, programmes 0 to 9 will be backed up by at least 1 hour in the event of a power failure. For this, see the GTV-BU 100 and GTV-BU 250 watt versions.



Tip: In mode 1, the GTV-I is Backward compatible with the previous GTV and GTVS power supplies and in position 0-9 with the GTV-A power supplies.

7.3 Detailed description of programmes 10 to 19 in combination with a Back-Up unit

Function switch position 10: UPS function test programme

<i>Enable output I and II independently of the status of the inputs.</i>		
Desired function	Input conditions	Results
Switch on outputs I and II	Operate PB	Outputs I and II active
Switch off outputs I and II	Operate PB	Outputs I and II fail

Function switch position 11: Programme 11: Preferred and non-preferred function

<i>Two loads (zones) switched on and off separately via output I and II, with output II protected against disconnection and equipped with Back-up</i>		
Desired function	Input conditions	Results
Switch on output I	Close inputs A & C	Output I active
In the event of a power failure	Inputs A & C closed	Output I fails
Switch off output I	Interrupt input A or C or operate PB	Output I fails
Switch on output II	Close input B	Output II active
In the event of a power failure	Input B closed	Output II remains active until the back-up unit is empty
Switch off output II	Interrupt input B	Output II fails

Function switch position 12: Programme 12: Sliding door control with optical and acoustic signalling

<i>Two loads (zones) switched on and off separately via outputs I and II.</i>		
Desired function	Input conditions	Results
Activate Output I holding magnet	Close inputs A & C	Output I active
In the event of a power failure	Inputs A & C closed	Output I fails after 15 seconds
Deactivate Output I holding magnet	Interrupt input A or C or operate PB	Output I fails
Flash activation	(if output I fails:)	Output II becomes active
Slow Whoop activation	(if output I fails:)	Output 6: becomes active
In the event of a power failure	(if output I has failed)	Output II remains active until Back-Up is empty
Turn off Slow Whoop	Input D close (limit switch)	Output 6: fails
Switch off flash	Close input E (Reset)	Output II fails
Reset	(if output II fails:)	Output I becomes active again if mains power is restored

If a TX module is connected, all programmes apply:

To bridge the start-up of an emergency generator in the event of mains power failure, the power supply must continue to feed the total load for at least 15 seconds, unless the selected programme dictates otherwise. Therefore, the right number and type of TX module must be selected.

After this time, the controlled shutdown routines are activated if necessary. (e.g. for a closing sequence control) The switch-on and switch-off conditions remain active during the entire back-up cycle.



Tip: More application examples can be found in our application manual on our webshop among the GTV-I products.

8 Commissioning the GTV-I

After the GTV-I is supplied with mains power and the function switch is set, the GTV-I will start up depending on the programme mode selected and the status of inputs A, B, and C. You can check the status of the inputs, and outputs via the LED signalling as described below.

The GTV-I power supply unit is supplied with 3 jumpers in inputs A, B and C as standard. If you do not use one of the inputs but it must be present as a start-up condition, do not remove the jumper.

8.1 Status LEDs on the GTV-I

Input and output status LEDs on the control board

The GTV-I has eight LEDs on the control board that allow the status of the device to be checked quickly and easily.

LED	Colour	Function
LED A	blue	Input A active
LED B	blue	Input B active
LED C	blue	Input C active
LED D	blue	Input D active
LED E	blue	Input E active

LED	Colour	Function
LED Power on	green	24 V DC power supply available
LED I	green	Output I active
LED II	green	Output II active

Load indicator

 <p>100% ⊗ 80% ⊗ 60% ⊗ 40% ⊗ 20% ⊗ current ⊗</p>	<p>Load indicator on PCB</p> <p>A unique feature of the GTV-I is the direct visual feedback of the load. The 6 LEDs give instant insight into the degree of load. This feature speeds up commissioning, helps prevent breakdowns and makes maintenance more efficient.</p>
---	--

Status LEDs on the door

 <p>● Power on ● Overcurrent ● Fault ● UPS mode*</p>	<p>Intuitive operation</p> <p>With four LED status indicators and integrated push-button controls, status diagnosis becomes very easy.</p>
---	--

8.2 Reset push button on the PCB

Reset push button SW2 control voltage present PWR Load indicator Function switch SW1 Jumper J6

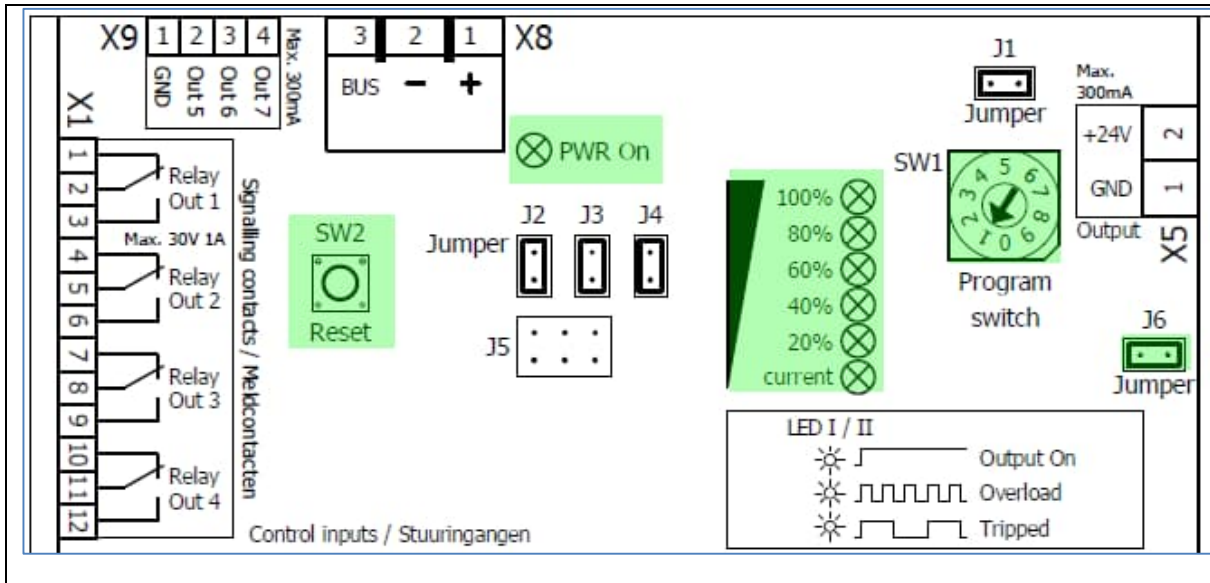

The GTV-I is fully overload protected.

8.3 Three-wire connection of 2 load circuits

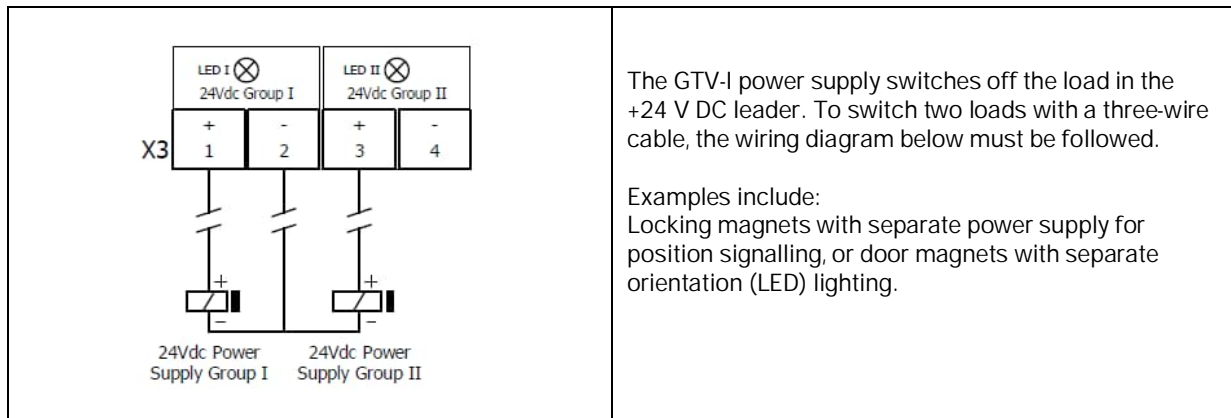

8.4 Forwarding of operational messages

The GTV-I provides four potential-free changeover contacts that can be used to transmit operational alarms, fault signals, and mains power failures to the BMS or the higher-level GBS system.

- Signal contact terminals 1, 2 and 3: changeover contact for Circuit I operational alarm
- Signal contact terminals 4, 5 and 6: changeover contact Circuit II operational alarm
- Signal contact terminals 7, 8 and 9: changeover contact for central fault alarm
- Signal contact terminals 10, 11 and 12: changeover contact for supply voltage present/absent

8.5 Master/follower line coupling

Master/follower line coupling:

The Master output (terminals 1 and 2 on terminal block X9) becomes active as soon as output A becomes active. This signal can be used to control other GTV-I units (follower mode). GTV-I units configured as "follower line" use input C at terminal 6 as follower line input. The GND (terminal 1 on terminal block X9) is interconnected.

GTV-I Master with GTV-I follower line control

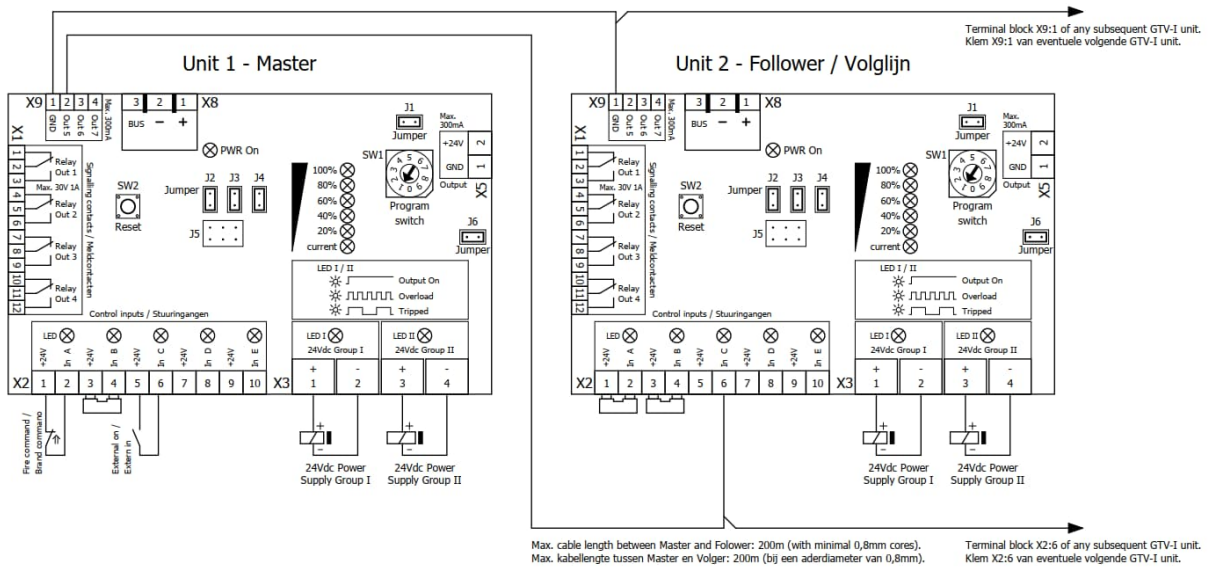

GTV-A Master with GTV-I follower line control

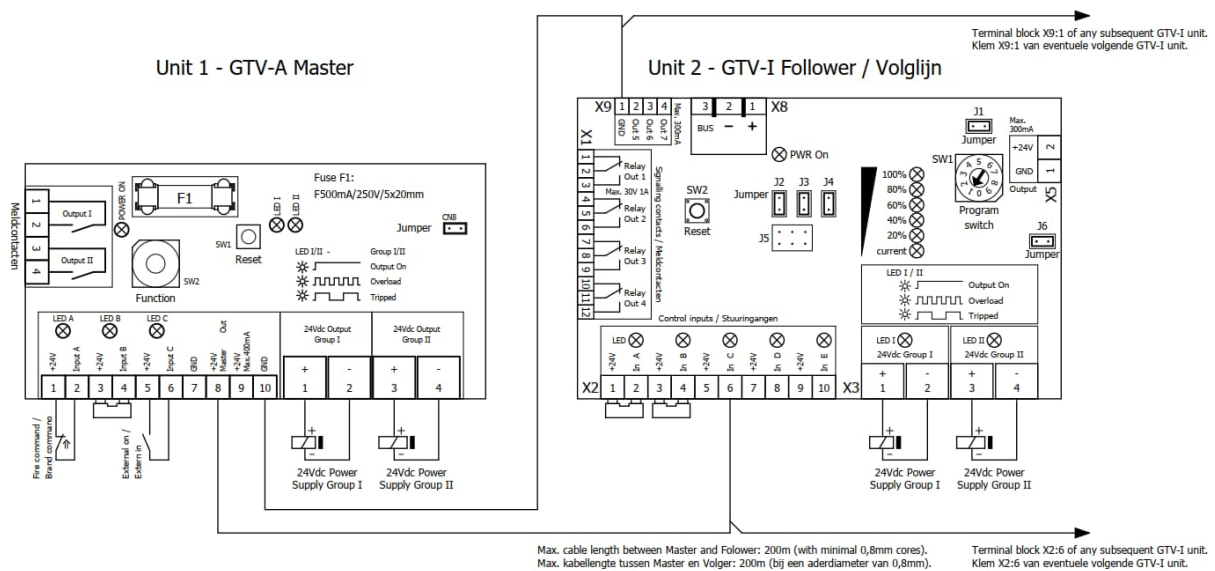

9 Status messages on the GTV-I

Optical status messages on the control board and on the front of the housing door

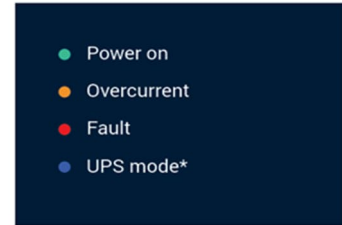
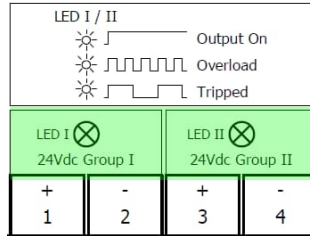

Load indicator on the control board messages on the door

Status messages on the control board

Status

LED status indicators on the door

LED colour	Meaning	Recommended action
	<p>Power On</p> <p>The current issued by the GTV-I is within the specified limit. The push button on the housing lights up as long as at least one of the outputs is active.</p>	No
	<p>Overcurrent</p> <p>The power supply is slightly overloaded and will switch off after 20 seconds.</p>	Reduce the load up to 100%
	<p>Fault</p> <p>The power supply switches off immediately in the event of excessive overload (> 1.5 times $I_{nom.}$) or internal fault message</p>	Remove the fault and reset the power supply
	<p>UPS mode available</p> <p>Stable backup power supply is connected</p>	No
	<p>UPS mode Active</p> <p>The GTV-I is powered via the TX backup Supercap modules or the GTV-BU battery back-up power supply.</p>	Restore power supply

Reset overcurrent and short-circuit protection

LED 1 or LED 2 on the control board indicates in which circuit the short-circuit or overload has occurred. Reduce the load on the GTV-I's outputs, then press the reset button on the control board (SW2) for about 2 seconds. If the fault source is still present, resetting will cause the power supply unit to immediately go back into fault.

10 Maintenance and management

General

The system administrator is responsible for correct management, inspection, and maintenance of the installation. This should be done in accordance with the provisions of NEN 2654-3 management, the inspection and maintenance of fire protection systems; Part 3 "Smoke control systems".

According to standard EN 2535, the GTV-I supply unit should be switched off at least once every 24 hours to test whether the doors are closing correctly.

If the GTV-I has been connected in accordance with all applicable standards, the aforementioned test function (e.g. built-in clock) will be incorporated in the system. Under normal operation, the GTV-I power unit does not require maintenance.

However, it is recommended to manually switch off the GTV-I power supply at least once every two months to test its functionality. This helps ensure the system continues to operate correctly.



NOTE: The GTV-I will continue to function during this test, so both the 230 V AC supply voltage and the outgoing 24 V DC voltage remain present.

10.1 Service and maintenance

General:

Service and control activities

- Switch off the GTV-I using the push button on the housing door.
- De-energise the GTV-I by unplugging it from the wall socket and/or turning off the main switch.

Perform work

- Then switch the main switch back on or plug in.
- Check the start condition associated with the set programme.
- The green LED on the front will or will not light depending on the programme set.
- Check the output currents. These can be read via the LED indicator.

11 Warranty

All our deliveries are made in accordance with our general sales and delivery conditions for the technological industry, issued by the FME/CWM association and filed at the Office of the District Court in The Hague on 19 April 2010 under no. 29/2010. A copy will be sent to you upon request.

We also apply the aforementioned FME/CNW conditions for warranty. GTV-I power supplies are covered by a warranty period of 12 months from delivery.

12 Technical specifications

Type description	: GTV-I power supply unit
Manufacturer	: Electroproject
Primary voltage	: 180-240 V AC (47/63Hz. 1-phase)
Rated output voltage	: 24 V DC (nominal) 25 V DC terminal voltage
Ripple voltage and noise	: <1 %
Rated output current	: Depending on type maximum 1, 2, 4, 10 amp max.
Rated output power	: Up to 25, 50, 100 or 250 watts, depending on type
Short-circuit-proof	: Yes
Protected against overload	: Yes
Efficiency	: > 86% (at full load)
Mains voltage bridging time	: Depending on type 28-60 ms. See also TX Back-Up modules

Environmental conditions





Operating temperature	: -10°C to +40°C
Derating	: > 40°C (2% per °C) Max. 50 °C
Storage temperature	: -20°C to +70°C
Relative humidity	: 30%...90% without condensation
Maximum installation altitude	: Installation is allowed up to 2 km above sea level
Installation conditions	: Maintain at least 100 mm clearance for convection cooling
Installation class	: II (Connect to a circuit of 16A or less)
Safety class	: I (device must be earthed)
Protection class	: IP 44 (GTV-I 25, 50 and 100) IP 21 GTV-I 250
Housing colour	: RAL 7035

12.1 Dimensions and weights

Size details:

Type	Power supply dimensions (wxhxd) in mm	Borehole dimensions (wxh) in mm	Weight in kg	Packaging dimensions (wxhxd) in mm
GTV-I 25	250 x 250 x 120	210 x 210	4.5	310 x 310 x 190
GTV-I 50	300 x 250 x 120	260 x 210	5.0	360 x 310 x 190
GTV-I 100	300 x 250 x 120	260 x 210	5.5	360 x 310 x 190
GTV-I 250	400 x 250 x 155	360 x 210	7.0	460 x 310 x 230

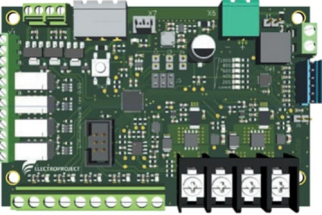
13 Spare parts and options

	<p>TX-1 Time Xtender Super-cap backup suitable for DIN-rail mounting.</p> <p>Item number : 400010836 Function : > 20 second Back-Up for GTV-I 25 and GTV-I 50 Voltage : 24 V DC Design : DIN rail compatible Dimensions (mm) : 25 x 118 x106 (W x H x D)</p>
	<p>TX-2 Time Xtender Super-cap backup suitable for DIN-rail mounting</p> <p>Item number : 400010837 Function : > 20 seconds Back-Up For GTV-I I00 Function : > 8 seconds Back-Up For GTV-I 250 * Voltage : 24 V DC Design : DIN rail compatible Dimensions (mm) : 25 x 118 x106 (W x H x D)</p> <ul style="list-style-type: none"> * Parallel switching is possible
	<p>Universal GTV-I control board no. E24010</p> <p>Suitable for all GTV-I models. Version with programme selector switch. Suitable for replacement purposes.</p> <p>Item number : 40010840</p>
	<p>Time switch option</p> <p>Analogue single-channel time switch for DIN-rail mounting with daily programme and 70-hour power reserve.</p> <p>Digital single-channel time switch for DIN-rail mounting with daily and weekly programmes, and 600-hour power reserve.</p> <p>Item number Analogue : 40003778 Item number Digital : 40003779 Manufacturer : Finder.</p>

14 CE marking and RoHS declaration

CE declaration

The terms on which this declaration is based:

Electroproject B.V., as the manufacturer of the GTV-I power supply units, hereby declares that—when the GTV-I power supply units are installed in accordance with the instructions in this manual—they comply with the following EU directives:

- 2014/35/EU : Low voltage directive
- 2014/30/EU : EMC
- 2011/65/EU : ROHS

Additional standards:

With regard to product and safety

- EN 62368-1 : 2014/AC:2015 Electrical Safety (LVD)
- EN1155: CPR (EU) 305/2011
- EN14637: 2007

With regard to EMC

- EN 61000-6-3:2007 + A1:2011 + AC:2012 Electromagnetic Compatibility (EMC)
- EN 61000-6-2:2005/AC:2005
- IEC 61000-3-2
- IEC 61000-4-2,-3,-4 : 2017

With regard to RoHS

- EN IEC 63000:2018 Restriction of Hazardous Substances (RoHS)

This conformity is signalled by the **CE** logo affixed to the inside of the housing.

Example of the GTV-I 25 type sticker

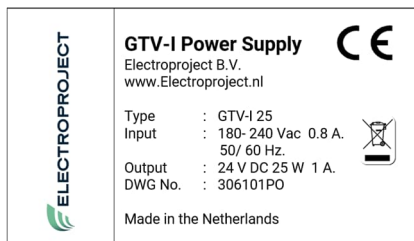

Date: 01-07-2025

Ir. Marco Jonker

Business Unit Manager Electroproject B.V.
Electroproject B.V.
Zaandam, the Netherlands

15 Contact with Electroproject

Helpdesk and support

If you would like support in resolving your fault, please contact our service department and ask for the helpdesk. You can reach them by calling: +31 (0)88 484 9283.

More information can be found at: www.Electroproject.nl

More information can be found at:



www.electroproject.nl

Electroproject B.V.
Albert Heijnweg 1
NL-1507 EH Zaandam
General phone number +31(0) 88 484 92 50
Helpdesk telephone number +31(0) 88 484 92 83
www.Electroproject.nl
sales@Electroproject.nl



Electroproject is ISO 9001 2015 and VCA-P 2017/6.0 certified